

8

7

6

5

4

3

2

1

INSTRUMENT PANEL

NOTE: SEE C071361 FOR ECU CONNECTION DIAGRAM

DUAL ECU SWITCHBOARD

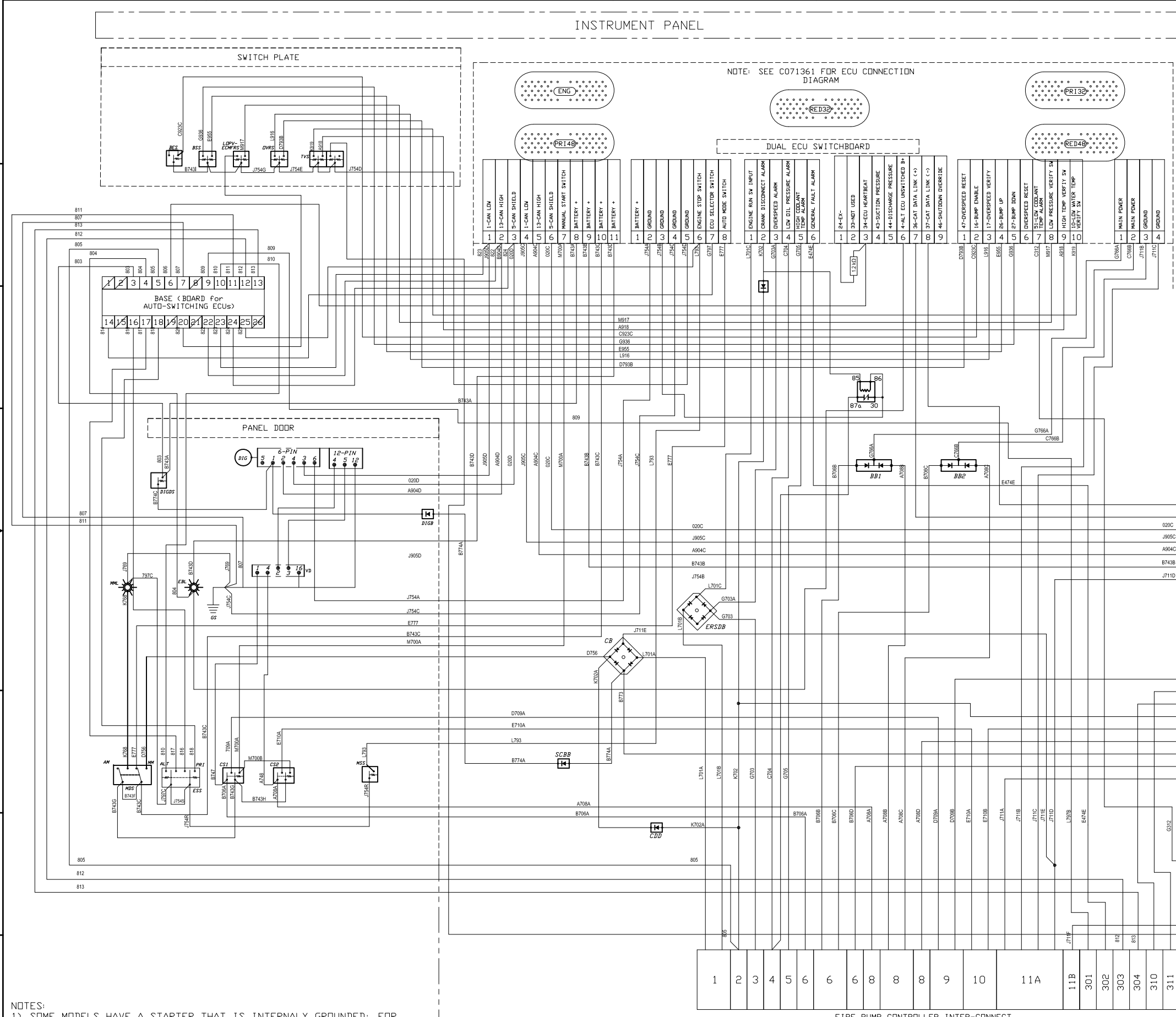

REV	DESCRIPTION	ECN#	DWN	APVD	DATE
--	ADDED CONTROLLED DRAWING NOTE	6309	MAL	MJD	24MAY21
B	CORRECTED TERMINATION OF OVERSPEED RESET WIRE, ADDED C13 ENGINES TO DESCRIPTION	6640	MJD	MJD	06JAN23

- AB - ALTERNATOR BRIDGE
- AL - ALTERNATOR
- AM - AUTOMATIC MODE POSITION
- B1 - BATTERY #1
- B2 - BATTERY #2
- BB1 - BATTERY BRIDGE #1
- BB2 - BATTERY BRIDGE #2
- BES - BUMP ENABLE SWITCH
- BSS - SPEED BUMP SWITCH
- BI - BATTERY ISOLATOR
- CS1 - CRANK (MANUAL) SWITCH - BATT#1
- CS2 - CRANK (MANUAL) SWITCH - BATT#2
- CB - COOLANT BRIDGE
- CDD - CRANK DISCONNECT DIODE
- DIA - DIAGNOSTIC GAUGE
- DIGB - DIAGNOSTIC GAUGE DIODE BRIDGE
- DIGDS - DIAGNOSTIC GAUGE DISPLAY SWITCH
- EBL - ALTERNATE ECU INDICATING LAMP
- ERSDB - ENGINE RUN SIGNAL DIODE BRIDGE
- ESS - ECU SELECTOR SWITCH
- GS - GROUND STUD
- HRWTS - HIGH RAW WATER TEMPERATURE SENSOR
- LFAB - LOW FLOW/TEMP ALARM BOARD
- LOPVS - LOW OIL PRESSURE VERIFY SWITCH
- MDS - MODE SELECTOR SWITCH
- MM - MANUAL MODE POSITION
- MML - MANUAL MODE INDICATING LAMP
- MP - MAGNETIC PICK-UP
- MSS - MANUAL STOP SWITCH
- OCB - OVER-CURRENT BREAKER
- DVRS - OVERSPEED VERIFY @ 67% / RESET SWITCH
- RWPS-H - RAW WATER PRESSURE SENSOR HIGH
- RWPS-L - RAW WATER PRESSURE SENSOR LOW
- SC1 - STARTER CONTACTOR BATT#1
- SC2 - STARTER CONTACTOR BATT#2
- SCB - SOLENOID CONTROL BOARD
- SCBB - SOLENOID CONTROL BOARD DIODE
- ST - STARTER
- THR - SCB THERMISTOR (COMPRESSOR INLET)
- TVS - TEMPERATURE ALARM VERIFY SWITCH
- VBS - BATTERY VOLTAGE SELECTOR
- VD - VOLTAGE DIVIDER
- VMG - VOLTMETER GAUGE
- WS - WATER TEMPERATURE VALVE
- WT - WATER TEMPERATURE N.O. SW 205°F

COLOR CODE

- A - WHITE
- B - RED
- C - ORANGE
- D - YELLOW
- E - GREEN
- F - GREEN
- G - BLUE
- G - BLUE
- I - PINK
- J - BLACK
- K - BROWN
- L - GRAY
- M - PURPLE

LEGEND

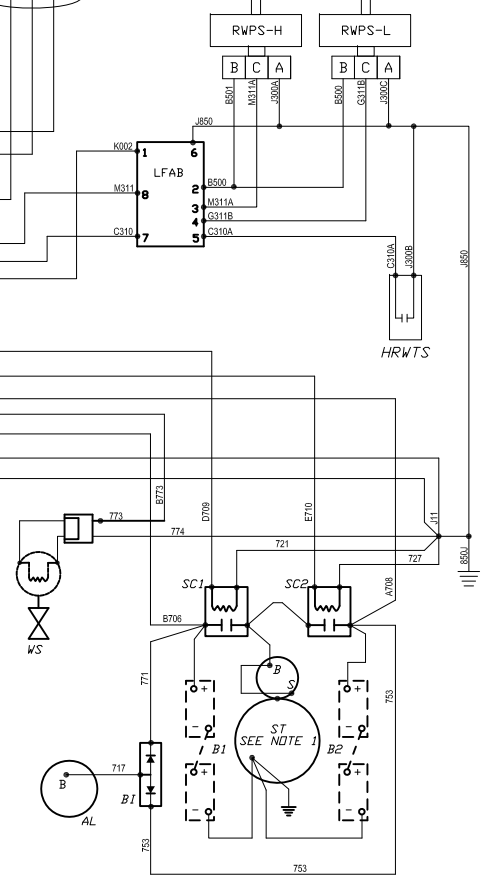
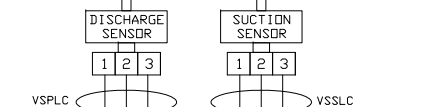

CONTROLLED DRAWING

THIS IS A REGISTERED PART WITH A THIRD PARTY AGENCY FOR USE ON A PRODUCT. NO SUBSTITUTIONS ARE ALLOWED. CONSULT ENGINEERING PRIOR TO AND REGARDING ANY CHANGE.

NOTES:
 1) SOME MODELS HAVE A STARTER THAT IS INTERNALLY GROUNDED; FOR THOSE THE BATTERY NEGATIVE CABLE (GRD) SHOULD BE ATTACHED TO THE ENGINE BLOCK (ALL PAINT SHOULD BE REMOVED TO BARE METAL)

THIS DRAWING AND THE INFORMATION HEREON ARE THE PROPERTY OF CLARKE AND MAY BE USED BY OTHERS ONLY AS AUTHORIZED BY US. UNLESS OTHERWISE ALL RIGHTS RESERVED UNDER THE COPYRIGHT LAWS.			
UNLESS OTHERWISE SPECIFIED TOLERANCES ARE:	DATE	DRAWN	NAME
DECIMAL: .125 IN	05APR18	MJDEMBKOWSKI	MJDEMBKOWSKI
FRACTIONAL: #1/32			
ANGULAR: ±.5°			
SIMILAR TO	USED ON / LAYOUT PART NO.	SCALE	UNITS
		NTS	MM [INCH]
		PAGE	OF
		1	1

CLARKE

WIRING DIAGRAM, C18 & C13 ENGINES

C072753

REV B

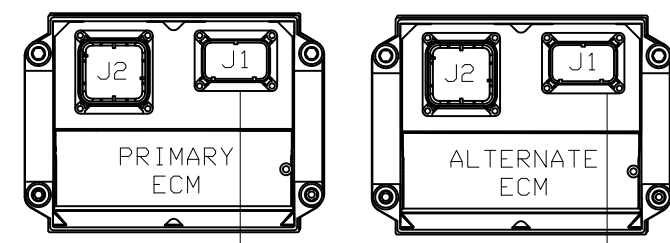
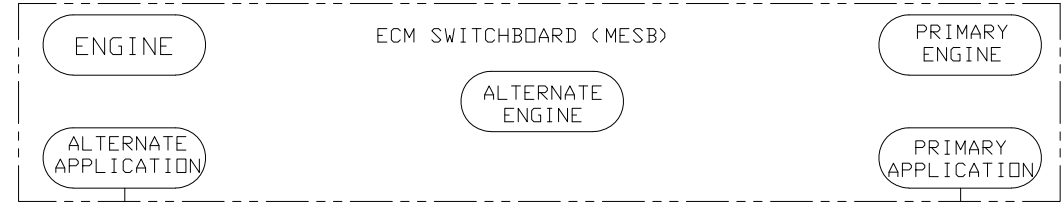

REV	DESCRIPTION	ECN#	DWN	APVD	DATE
A	ISSUED ENGINEERING DRAWING	5098	MJD	MJD	05APR18
B	ADDED DIODE TO APPLICATION HARNESSES	6050	MJD	MJD	17FEB20
C	ADDED HIGH COOLANT TEMP ALARM TO APPLICATION PIN CHART, C13 ENGINES TO DESCRIPTION	6179	MDM	CJR	06JAN23

MESB APPLICATION CONNECTORS TO PRIMARY & ALTERNATE ECU J1

SWITCHBOARD CONNECTION (MESB BOTTOM LEFT AND BOTTOM RIGHT)	DESCRIPTION	CAT ECM CONNECTION - J1 (PRIMARY & ALTERNATE)
1	SAE J1939 Low	34
5	CAN Shield	42
8	High Coolant Temperature Alarm	19
10	Low Coolant Temperature Test Switch Input	18
13	SAE J1939 High	50
16	Bump Enable	56
17	Switch In 3 - Overspeed Verify Enable Input	54
18	Source Drv 3 - Low Oil Pressure Alarm	11
20	Switch In 2 - Full Throttle - Grounded	69
26	Bump Up	58
27	Bump Down	60
28	Source Drv 2 - Overspeed Alarm	20
31	System Ground	63
34	ECM Heartbeat	21
36	CAT Data Link +	8
37	CAT Data Link +	9
38	1000 rpm (Source Driver 1)	13
46	Intermediate speed	45
50	Warning Lamp	10
51	Low Coolant Temperature Alarm	12
53	System Ground	65

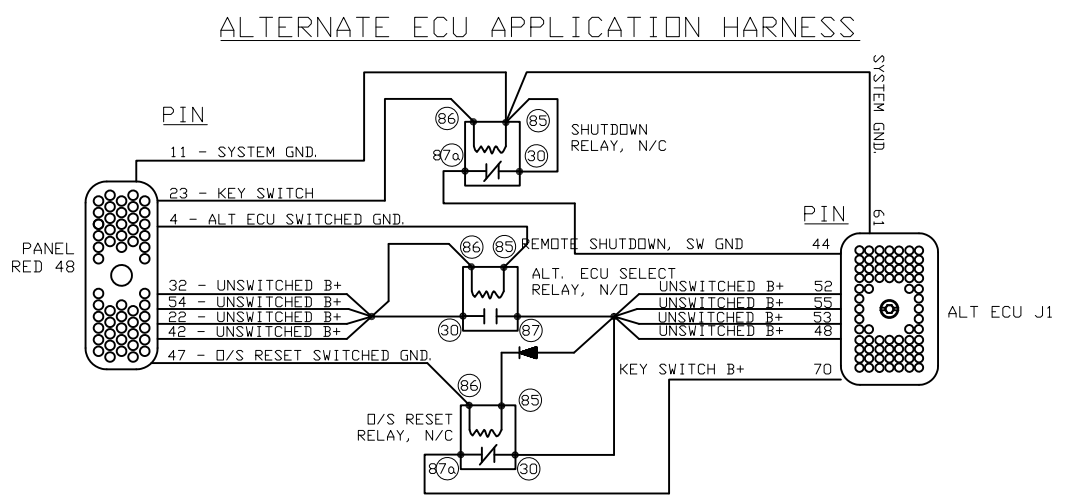
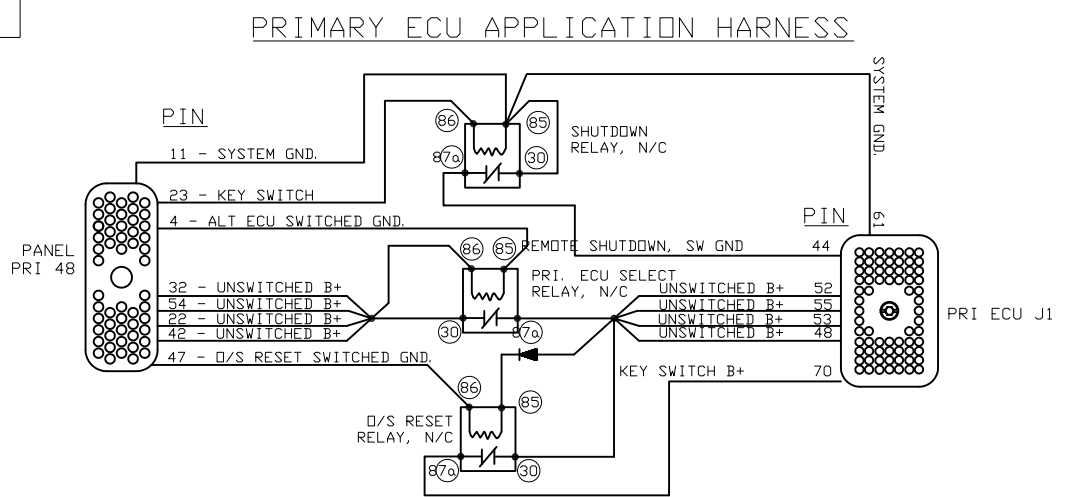

NOTE: SEE PAGE 2 FOR ECU J2 CONNECTIONS

CONTROLLED DRAWING
 This is a registered part with a third party agency for use on an approved/listed fire pump driver. No substitutions are allowed. Consult engineering prior to and regarding any change.

THIS DRAWING AND THE INFORMATION HEREON ARE OUR PROPERTY AND MAY BE USED BY OTHERS ONLY AS AUTHORIZED BY US. UNPUBLISHED - ALL RIGHTS RESERVED UNDER THE COPYRIGHT LAWS.		<input checked="" type="checkbox"/> YES <input type="checkbox"/> NO CONTROLLED DRAWING		
MACHINE TOLERANCES DECIMAL .001" .001" .001" % ±1.5 ±0.8 ±0.08 .XX ±0.3 ±0.03 .XXX ±0.025 ±0.01 .XXXX ±0.01 ±0.001 ANGULAR: ±0.5°		DRWN MJDEMBKOWSKI DATE 29MAR18 ENGR MJDEMBKOWSKI	NAME WIRING DIAGRAM, C18 & C13 ECU PART NO. C072736 REV C	
FABRICATION TOLERANCES DECIMAL .03 .03 .03 % ±1.5 ±0.12 ±0.06 .XX ±1.5 ±0.12 ±0.06 .XXX ±1.5 ±0.12 ±0.06 ANGULAR: ±1.0°		MATERIAL SIMILAR TO C071361	USED ON/LAYOUT PART NO. C18 & C13 UNITS MM [INCH]	PAGE 1 OF 2

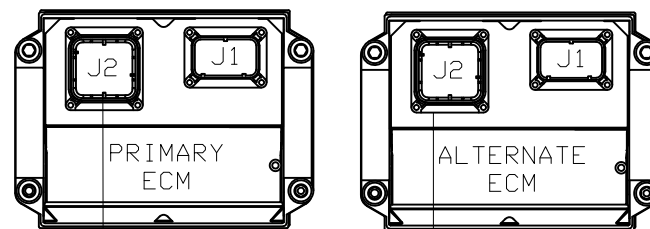
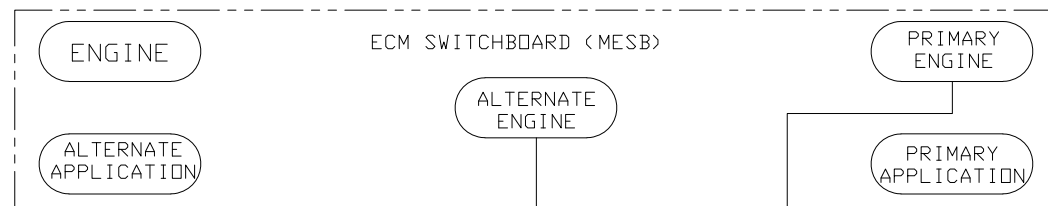

MESB ENGINE CONNECTORS TO 31 PIN ADAPTER TO PRIMARY & ALTERNATE ECU J2

DESCRIPTION	31 PIN DEUTSCH INTERCONNECT	SWITCHBOARD CONNECTION (MESB MIDDLE AND TOP LEFT)	CAT C18 ECM CONNECTION - J2 PRIMARY & ALTERNATE	CAT WIRE COLOR	CAT WIRE NUMBER	CAT AWG
Crank Speed	8	3	35	WHITE	E964	18
Coolant Temperature	1	4	13	BLUE	995	18
Fuel Temperature	15	5	62	YELLOW	F421	18
Injector Low 5 (cyl 4)	22	7	108	BLUE	T960	16
Injector Low 4 (cyl 2)	25	8	118	YELLOW	T958	16
Injector Low 2 (cyl 3)	20	9	106	BROWN	T959	16
Injector Low 1 (cyl 5)	21	10	107	GREEN	T961	16
Sensor Return 2	3	13	17	GREEN	G829	18
Cam Speed	11	14	46	YELLOW	E966	18
Intake Manifold Temperature	13	15	56	BLUE	C967	18
Oil Pressure	6	17	28	GRAY	994	18
Injector Low 3 (cyl 6)	19	18	105	WHITE	T962	16
Inject High 3,4	23	21	115	WHITE	T859	16
DeltaTemp Return	7	27	30	PINK	G833	18
TDC Service Probe (-)	9	28	36	YELLOW	G857	18
Injector Low 0 (cyl 1)	24	31	116	PURPLE	T957	16
Excitation Voltage 2	16	33	72	WHITE	G828	18
Crank Speed Return	4	35	25	BLACK	E963	18
Manifold Air Pressure	2	37	15	PINK	R746	18
Fuel Pressure	10	38	40	PINK	C991	18
Cam Speed Return	12	43	47	BLUE	E965	18
TDC Service Probe (+)	5	50	26	WHITE	G856	18
Atmospheric Pressure Sensor	14	52	57	GRAY	R747	18
Inject High 5, 6	17	53	99	ORANGE	T860	16
Inject High 1, 2	18	54	104	GRAY	T858	16

NOTE: SEE PAGE 1 FOR ECU J1 CONNECTIONS

CONTROLLED DRAWING

This is a registered part with a third party agency for use on an approved/listed fire pump driver. No substitutions are allowed. Consult engineering prior to and regarding any change.

THIS DRAWING AND THE INFORMATION HEREON ARE OUR PROPERTY AND MAY BE USED BY OTHERS ONLY AS AUTHORIZED BY US. UNPUBLISHED—ALL RIGHTS RESERVED UNDER THE COPYRIGHT LAWS.

YES NO
CONTROLLED DRAWING

DRWN MJDEMBKOWSKI NAME
DATE 29MAR18
ENGR MJDEMBKOWSKI

CLARKE
WIRING DIAGRAM,
C18 & C13 ECU

MATERIAL PART NO. C072736 REV C

SIMILAR TO C071361 USED ON/LAYOUT PART NO. C18 & C13 UNITS MM [INCH] PAGE 2 OF 2

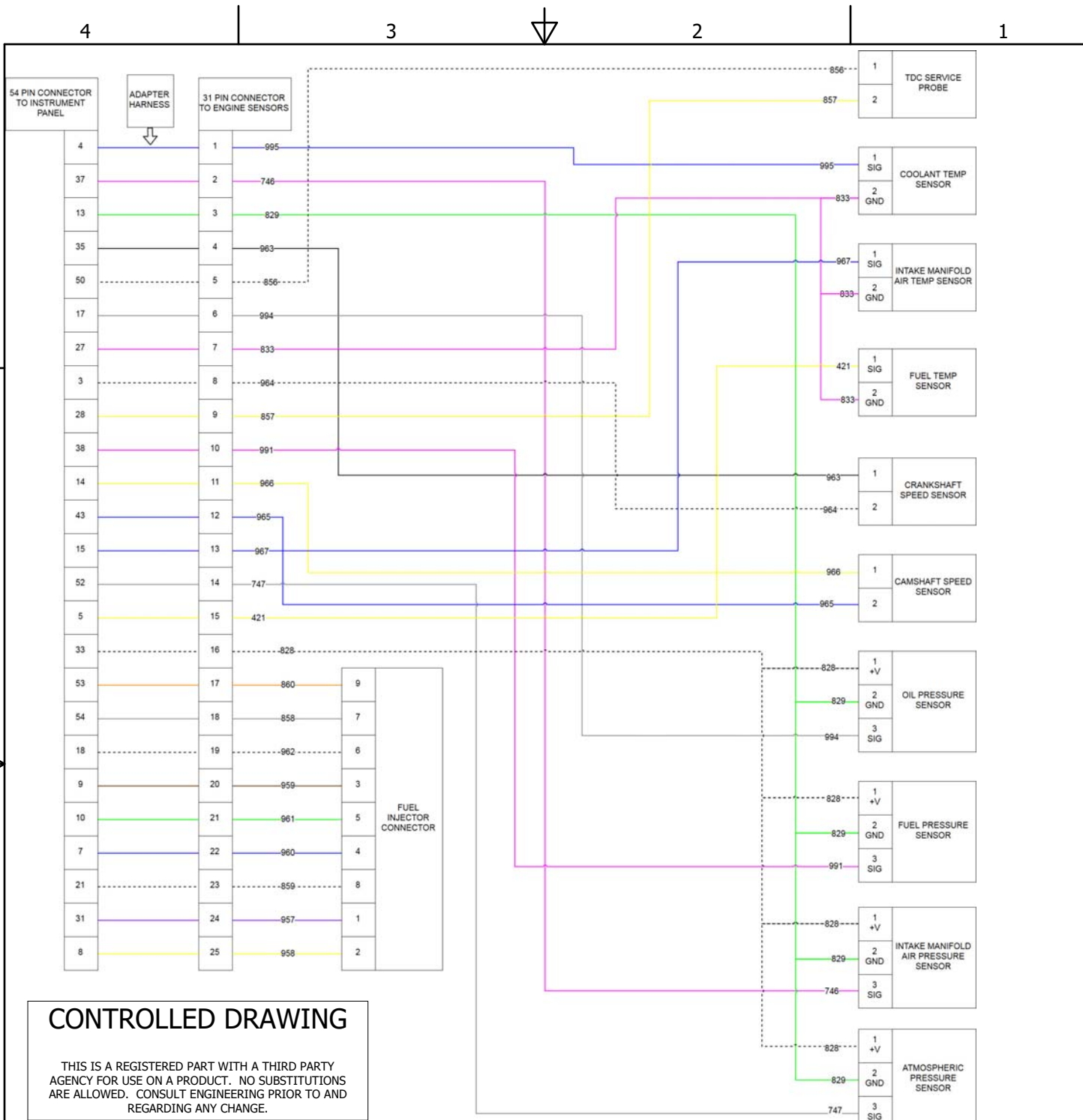

CONTROLLED DRAWING

THIS IS A REGISTERED PART WITH A THIRD PARTY AGENCY FOR USE ON A PRODUCT. NO SUBSTITUTIONS ARE ALLOWED. CONSULT ENGINEERING PRIOR TO AND REGARDING ANY CHANGE.

REV	DESCRIPTION	ECN#	DWN	APVD	DATE
-	ADDED C13 ENGINES TO DESCRIPTION	6179	MDM	<i>CLR</i>	06JAN23

<p>THIS DRAWING AND THE INFORMATION HEREON ARE OUR PROPERTY AND MAY BE USED BY OTHERS ONLY AS AUTHORIZED BY US UNPUBLISHED--ALL RIGHTS RESERVED UNDER THE COPYRIGHT LAWS</p> <p>UNLESS NOTED OTHERWISE, TOLERANCING GUIDELINES WILL BE AS SHOWN BELOW</p> <p>MACHINE TOLERANCE</p> <table border="1"> <thead> <tr> <th>DECIMAL</th> <th>mm</th> <th>inch</th> </tr> </thead> <tbody> <tr> <td>X</td> <td>± 1.5</td> <td></td> </tr> <tr> <td>X.X</td> <td>± 0.8</td> <td>± 0.06</td> </tr> <tr> <td>X.XX</td> <td>± 0.3</td> <td>± 0.03</td> </tr> <tr> <td>X.XXX</td> <td></td> <td>± 0.01</td> </tr> </tbody> </table> <p>ANGULAR: ± 0.5°</p>	DECIMAL	mm	inch	X	± 1.5		X.X	± 0.8	± 0.06	X.XX	± 0.3	± 0.03	X.XXX		± 0.01	<input checked="" type="checkbox"/> YES <input type="checkbox"/> NO CONTROLLED DRAWING	<h1>CLARKE®</h1>	
	DECIMAL	mm	inch															
	X	± 1.5																
	X.X	± 0.8	± 0.06															
X.XX	± 0.3	± 0.03																
X.XXX		± 0.01																
DRWN MJDEMBKOWSKI DATE 4/5/2018 ENGR MJDEMBKOWSKI	<h2>WIRING DIAGRAM, ENGINE SENSORS, C18 & C13</h2>		PART NO. C072754 REV A															
MATL ASSM C18 & C13 SIMILAR TO ORIGINAL PART	SCALE NTS	UNITS MM [INCH]		PAGE 1 OF 1														

4 3 2 1

D

C

B

D

C

B

A

A

4 3 2 1